

Operating Manual Piston Pump

Mex 0831-10/100-199

Mex 0831-11/600-699

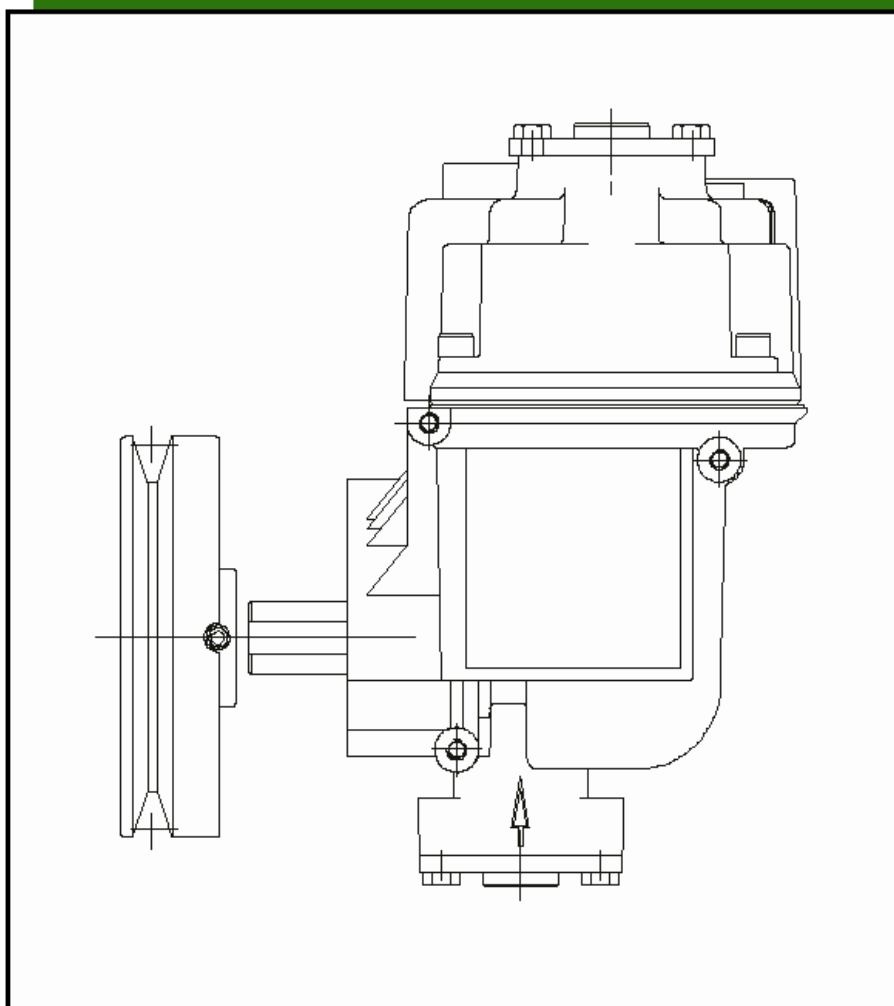

CE 0102

PTB01ATEX5004

EX II 2(1) G IIA T3
II G IIA

WWW.duerr-technik.com

Preface

This operating manual is valid for the piston vacuum pump for gas recovery, type MEX 0831-10/100-199 and MEX 0831-11/600-699.

The operating manual is only valid in so far as the piston vacuum pump for vapour recovery fits the description described within.

These instructions contain all details which are necessary for transport, assembly, operation, maintenance and shut down of the piston vacuum pump.

Therefore please read the operating manual carefully, before the first operation, to ensure the safe deployment of the piston vacuum pump for vapour recovery.

When a fault occurs or maintenance is required which is not dealt with in this manual, you must contact our technical engineers.

All maintenance and service work must be carried out by qualified personnel. If maintenance or repair work is neglected or not properly carried out, our guarantee will be invalidated.

Should you, after reading this manual, still have any problems, our trained personnel will be pleased to help you.

We wish you a problem and fault free working environment.

The information in this document can be altered without prior announcement.

No part of these pages may, for any purpose, be duplicated or used either in writing or electronically, without written permission of the company Dürr Technik,

© 2006 Dürr Technik
All rights reserved.

The use of brand names, trade names, trade marks etc. in this document are covered by trademark legislation and it must not be assumed to be free to use.

This technical handbook corresponds with the technical standard of our piston pumps , subject to alterations and errors accepted.

The management Dürr Technik

Dürr Technik
Dürr GmbH + Co. KG
Luft- und Processor-Technik
Pleidelsheimer Straße 30
74321 Bietigheim-Bissingen
Telefon 0 71 42 / 90 22 0
Telefax 0 71 42 / 90 22 99

List of contents		Page
	Preface	2
1.	Safety regulation and advice	4
1.1	Safety regulation and general advice	4
1.2	Safety advice	4
1.3	Emphasis	5
1.4	Symbols	5
2.	Transport, Storage, Initial operation	5
2.1	Transport and storage	5
2.2	Terms of transport and storage	5
2.3	Assembly and initial operation	5
2.4	Mounting conditions	5
2.5	Technical description and special conditions	6
Image.1	Construction	7
3.	Installation	8
3.1	Installation advice and positioning	8
3.2	Fixing	8
3.3	Pulley and belt drive	9
3.4	Electrical equipment	9
3.5	Flame arrester and pipe connections	10
Image.4	External dimensions	11
4.	Servicing	12
4.1	Maintenance	12
4.2	Troubleshooting	13
5.	Technical advice	14
5.1	Spare parts service	14
5.2	Delivery terms	14
5.3	Repairs	14
6.	Spare part list	15
7.	Technical data	15
8.	Declaration of conformity based on directive 94/9/EC	16

1. Safety regulations and safety advice



Caution!

Please read carefully and observe the operating instructions to avoid mistakes and dangerous situations.

1.1 Safety regulations and general advice

When working with or on the piston pump the following regulations and guidelines must be observed.

EN 60 079-10 (IEC 60079-10)

Electrical apparatus for explosive gas atmospheres
Part 10: Classification of hazardous areas

EN 60 079-14 (IEC 60079-14)

Electrical apparatus for explosive gas atmospheres
Part 14: Electrical equipment in hazardous areas

EN 50 014

Electrical apparatus for explosive gas atmospheres
General requirements

Specific country safety regulations
Specific country environmental regulations
Specific country health and safety regulations

TUV Rhineland bulletin:

Supervision of Vapour Recovery Systems.

1.2 Safety device

The following advice for the guarantee of industrial protection and safety should be observed:

- The safety guidelines mentioned in para.1.1
- When operating the piston pump the relevant laws and regulations for the region must be observed. In the interest of a safe working procedure, the operator(s) and supervisor(s) are responsible for enforcing the regulations.
- All assembly, maintenance and repair work must be carried out by qualified personnel.
- The advice labels on the machine must be observed.
- The removal of, or making safety devices ineffective, is not permitted.
- The pump must be disconnected from the electricity supply, before any maintenance or repair work is carried out.
- Personnel using the machine should be fully conversant in its use.

1.3 Emphasis

In the text the following symbols and directives are used to point out unusual features or dangers.



Caution !

This symbol together with the directive "CAUTION" will be used when incorrect or non-compliance of operating instructions, working instructions, stipulated work procedures and such like could lead to injuries, fatal accidents or else the loss of the registered licence cover.



Attention !

This symbol together with the directive "ATTENTION" will be used when incorrect, or non-compliance of operating instructions, working instructions, stipulated work procedures and such like could cause damage to the machine.



Comment !

This symbol together with the directive "COMMENT" will be used when something unusual is pointed out.

1.4 Symbols



Please note the accompanying documents



Please note the siting of the pump (see section 4.1)



Take account of ambient conditions!

2. Transport, storage and initial operation

2.1 Transport and Storage

The piston vacuum pump is packed in a transport carton at the factory

This ensures that no damage to the machine will occur during transportation.

The machine will be protected against damage, moisture and extreme temperatures.



Protect the appliance during transport and storage against moisture and extreme temperatures

The oil-free piston vacuum pump is ready for immediate operation. Piston vacuum pumps which are in their original packing can be stored in dry, dust-free rooms. If a piston vacuum pump is to be stored long term, e.g. a replacement pump, it must be protected against pollution.



Dispose of the packing material in an ECO suitable manner. The carton can be recycled.

2.2 Storage and transport conditions

Temperature : - 25 °C to 55 °C

Relative humidity : 10% to 90%

2.3 Installation and Initial operation

Assembly and initial operation must be carried out by qualified specialists used to handling the machines.

2.4 Ambient conditions

The piston vacuum pump must be easily accessible for the maintenance of the flame arrester.

During installation of the piston vacuum pump, allowance should be made to allow the model label to be easily read.

2.5 Technical description and special condition

Special conditions

The vapour recovery pumps types

MEX 0831-10 / 100 - 199

MEX 0831-11 / 600 – 699

may only be used in vapour recovery devices at filling stations for sucking off fuel vapour/air mixtures.

The vapour recovery pumps are to be earthed electrostatically.

The flame arresters (and components including the latter) are to be subjected to a visual check, above all for contamination and corrosion, at suitable intervals of time and to be cleaned or replaced if need be.

The operating temperature in the outlet line may not exceed $95^{\circ}\text{C} \pm 5^{\circ}\text{C}$.

The operating overpressure in the outlet line compared with atmospheric pressure may not exceed 150 mbar (150 hPa).

In the use of vapour recovery pumps types "MEX 0831-10" and "MEX 0831-11" as a **protective system**, the following conditions must additionally be complied with or fulfilled:

Max. hose and pipe lengths between dispensing valve and vapour recovery pump:

- a) gas return hose with an internal diameter ≤ 10 mm in a coaxial hose ≤ 6 m, or optionally
- b) coaxial hose with an outer diameter ≤ 38 mm, length ≤ 6 m together with a subsequent DN 15 pipe (G ½), length ≤ 3 m.
- c) in addition one of the following vessels may be installed in line with the subsequent pipe:

- pulsation damper 250 ml from factory Scheidt&Bachmann, no.0582542 or
- condensate trap from factory Fafnir no.XO 013001

The vessel has to be installed in a distance between 0,3 m to 2,5 m before the pump while the minimum length between the pipe and the hose has to be 0,5 m.



Caution!

The sucked vapours and liquids must belong to the explosion group IIA with a standard gap $\geq 0,90$ mm.



CAUTION !

Other applications especially the delivery of mixtures, capable of explosion, beyond the above described case of application, are not permitted and could possibly lead to great personal and property damage.

Function description

The following description refers to the **fig.1**. The piston pump works on the floating piston principle, i.e. piston rod and piston form a rigid unit.

The variable values between the floating piston (4) and the valve plate (3) and cylinder (9) during further explanations will be called piston displacement.

The turning of the shaft (6) is converted via the crank (5) into an oscillating movement of the floating piston.

During each complete rotation of shaft (6) a underpressure is created in the crank case (1) during the upward movement of the floating piston (4) by the piston displacement.

Through the pressure difference the inlet valve opens and gas is aspirated out of the crank case.

During the upward movement of the floating piston, the gas in the piston displacement area is compressed until the pressure is sufficient to open the outlet valve or close the inlet valve.

The aspirated gas volume is expelled via the flame arrester (39) at the outlet side.

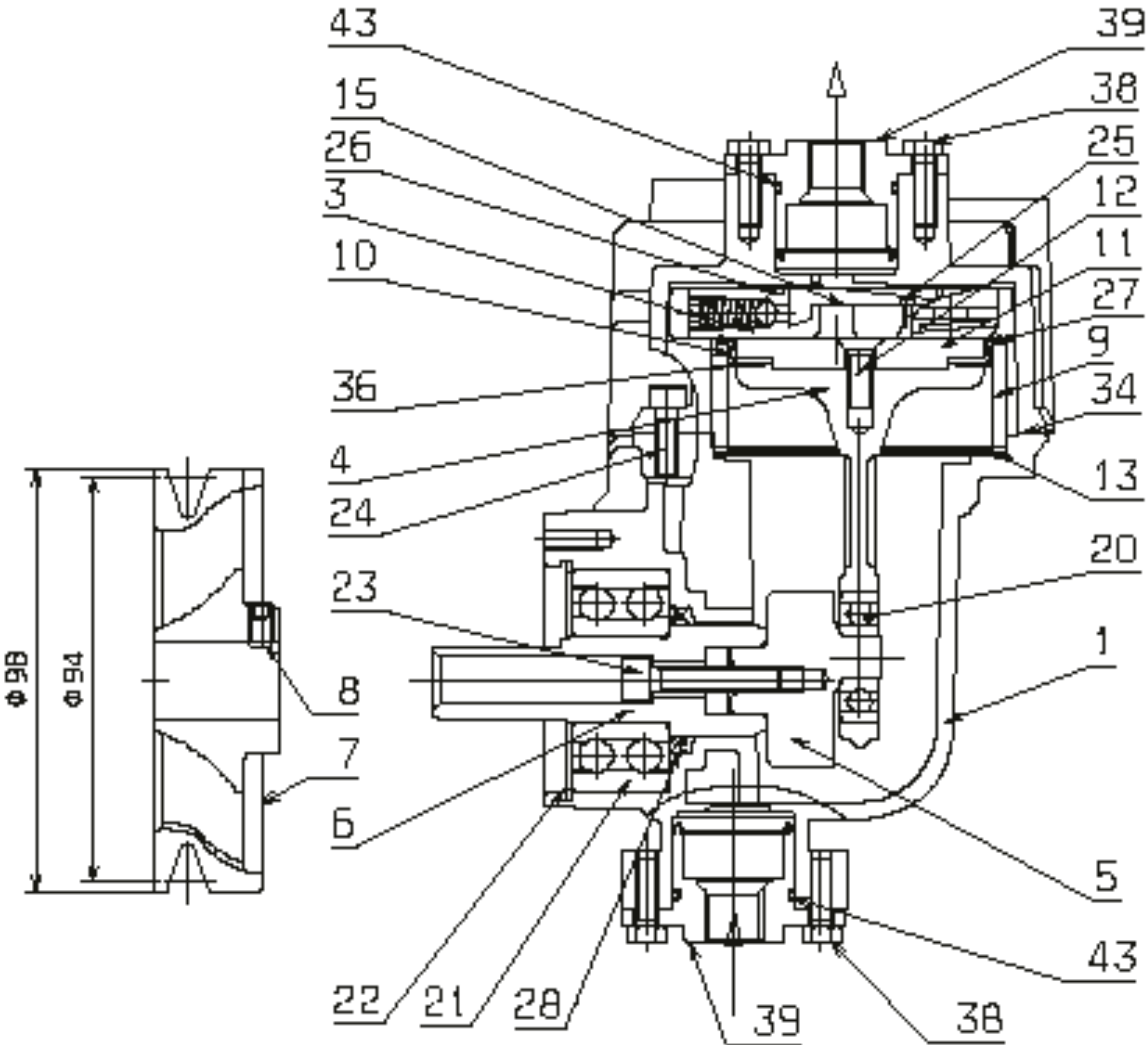

fig. 1

3. Installation

3.1 Installation advice and positioning

To avoid the pump being completely filled with condensate, the fitting positions as shown in fig. 3 must be adhered to.



Caution !

Incorrect fitting can possibly severely reduce the lifespan of the pump and make void the manufacturers guarantee.

3.2 Fixing

For fitting the pump within the petrol pump there are female threads M5 x 11 provided for each side surface and on the shaft side of the pump case (see fig. 3)

Fixing at three connection points of one side is sufficient.

Einbaulege / Position of installation / Position de montage
 Posizione di montaggio / Sitio de instalacion

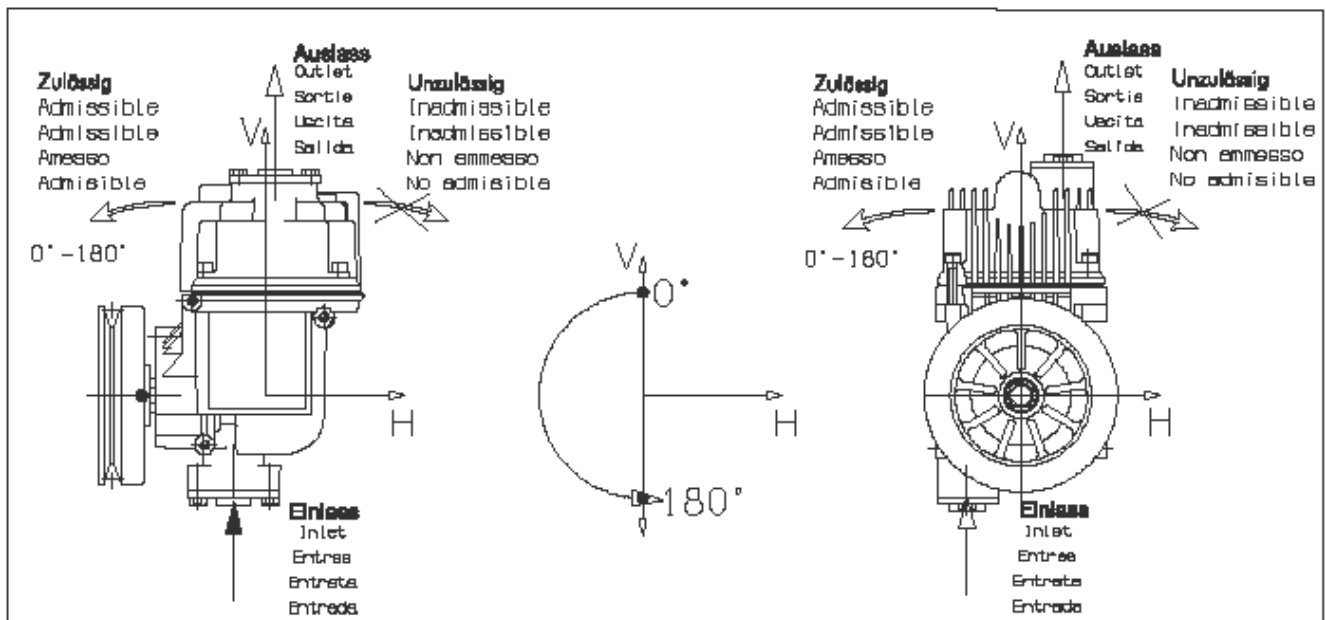

Links- oder Rechtslauf
 Rotation left or right

Fig.2

Permitted and non-permitted fitting positions for MEX 0831-10 and MEX 0831-11

3.3 Pulley and beltdrive



Only use electrically conductive drive pulleys. To ensure fault-free function of the piston pump and prevent excessive wear of belt and bearings, it is necessary

- to regularly check the belt tension.
- broken or damaged belts must be replaced
- the motor and pump belt pulley should be in exact alignment.

The fan pulley (fig.1 pos. 7) must only be mounted in the shown position onto the axle.

The permitted positioning area on the axle must be adhered to. (see fig 4)

For the MEX 0831-10 version only use fan pulleys specified by the manufacturer.

During the assembly of the fan pulley the fan action on the pump must not be impaired through covering it or such like.

Blows to the shaft or the fan pulley must be avoided, besides causing damage to the main bearings, the result could be loss of flashback safety.

Through this the lifespan and operating safety would be clearly reduced.

Recommended belt profile:

Belt type	Profile
Small cone belt	SPZ / XPZ

Recommended key widths and torque value for the attachment screw:

Key width [mm]	Ley length [mm]	Torque [Nm]
3	100	5+1



Comment!

To loosen or tighten the attachment screw (fig.1 pos. 8) only use an undamaged hexagonal allen key.

3.4 Electrical equipment



Caution!

The piston pump must only be operated by a motor which complies with the following specifications.

DIN EN IEC 60079-10

Electrical apparatus for explosive gas atmospheres

Part 10:

Classification of hazardous areas

DIN EN IEC 60079-14

Electrical apparatus for explosive gas atmospheres

Part 14:

Electrical equipment in hazardous areas

3.5 Flame arrester and pipe connection



Caution!

The piston pump, for technical safety reasons, must not be operated without the flame arrester specified by the manufacturer.

When connecting the gas return lines the points raised in para. 2.5 must be observed.

For connection to the gas pipe the flame arrester has a standard G ¼ female thread. In some custom made units an NPT ¼" female thread is made available and can be identified by markings on the front side recess.

The suction side connection (from nozzle) of the piston pump is marked with an arrow (see **fig 4**).

4. Servicing

Section 4 contains all the necessary details for carrying out the servicing procedure. Should a fault occur or repair work be required which is not dealt with in section 4, our technicians must be contacted.

4.1 Maintenance

Within the type approval the user is **obliged** to make a visual check of the flame arrester, at appropriate intervals of time. (fig.1, pos. 39) for dirt and corrosion then, if necessary, clean or change it. **Only Dürr original parts must be used, otherwise the type approval will be cancelled.**

For testing, the flame arresters (pos.39) can be completely detached off the pump. First both M5x16 screws (pos. 38) have to be unscrewed with the wrench size 8. There after the flame arresters can be removed at the flange out of the pump. Greasing the O-ring before mounting is recommended. The flame arresters should be rescrewed with hexagon screws (pos. 38) to the pump casing.

Torque: 5 ⁺¹ Nm

Please guard the threads with anaerobic glue.

White spirit is suitable as a cleaning agent during cleaning the instructions of the attached safety data sheets must be observed as per 91/155/EWG.



Comment!

To ensure fault free function of the piston pump and prevent excessive wear of belt and bearings, it is necessary

- **to regularly check the belt tension.**
- **broken or damaged belts must be replaced**
- **the motor and pump belt pulley should be in exact alignment.**

4.2 Troubleshooting		
Condition	Possible cause	Remedy
Pump does not start	Power supply failure	Check mains power, equipment fuses and power line connections.
	Power supply too low	Check mains power supply
	Control defective	Check control
	Mechanical sluggish	Factory repair
	Ambient temperature too high – temperature switch shuts off	Check / Improve ventilation
	Start capacitor of motor defective	Check start capacitor Factory repair
Bad flow	Measuring system not o.k.	Check measuring system and if necessary correct it or else exchange it.
	Control defective	Check control
	Flow losses in suction line	Enlarge pipe diameters, pipe length and the number of returns Check pipes for mechanical damage (e.g. kinking)
	Flame arresters dirty	Clean or else change them
	Control valve dirty or defective	Clean or else change it
	Piston or shaft casket worn down	Factory repair
	Valves dirty or broken	Factory repair
	Mechanical sluggish	Factory repair
	Motor speed too low	Check mains power
Flow too high	Liquid in the (bellow) gas meter Measuring device defective	Check measuring device and if necessary clean or change it.
Pump noisy	Vibrations are transmitted to surroundings	Check installation and if necessary buffer the affected area or reposition the support etc. Use flexible metal gas hose !
	Pump or motor bearings defective	Factory repair

5. Technical advice

Dürr Technik
Dürr GmbH & Co. KG
Luft-undProcessor-Technik
Pleidelsheimer Straße 30
74321 Bietigheim-Bissingen
Telefon 0049 7142 / 90 22-0
Telefax 0049 7142 / 90 22 99

5.1 Spare parts

Spare parts orders to be sent in accordance with the available spare parts list, in writing to the above address or by telephoning the following phone numbers:

Phone : 0049 (0) 7142 / 90 22 31
Fax : 0049 (0) 7142 / 90 22 99

For spare parts orders the following details are required:

Model number of the pump
Order number as per the parts list
Quantity required
Delivery address
Dispatch details

5.2 Terms of delivery

Delivery according to our sales, delivery and payment terms.

5.3 Repairs / Return delivery

Always pack the pump in a plastic bag.
Choose solid packaging to protect appliance against further damage.
Only use recyclable packing material.

6. Parts list

Position (Fig.1)	Description	Order no.
7;8	Fan pulley incl. set screw	0831-006-00
39	Flame arrester G1/4	0831-007-00
39	Flame arrester NPT1/4	0831-008-00
43	O-ring for flame arrester	900-402-72

7. Technical data

Type	Suction pressure (absolut)	Flow	Recommended drive power	Maximum speed	Noise level (*)
	[mbar]	[l/min]	[W]	[1/min]	[dB(A)]
0831-10 / 1XX	~ 150	43	150	2100	< 70
0831-11 / 6XX	~ 150	44	150	2300	< 70

(*) : Noise level based on EN ISO 2151 and EN ISO 3744

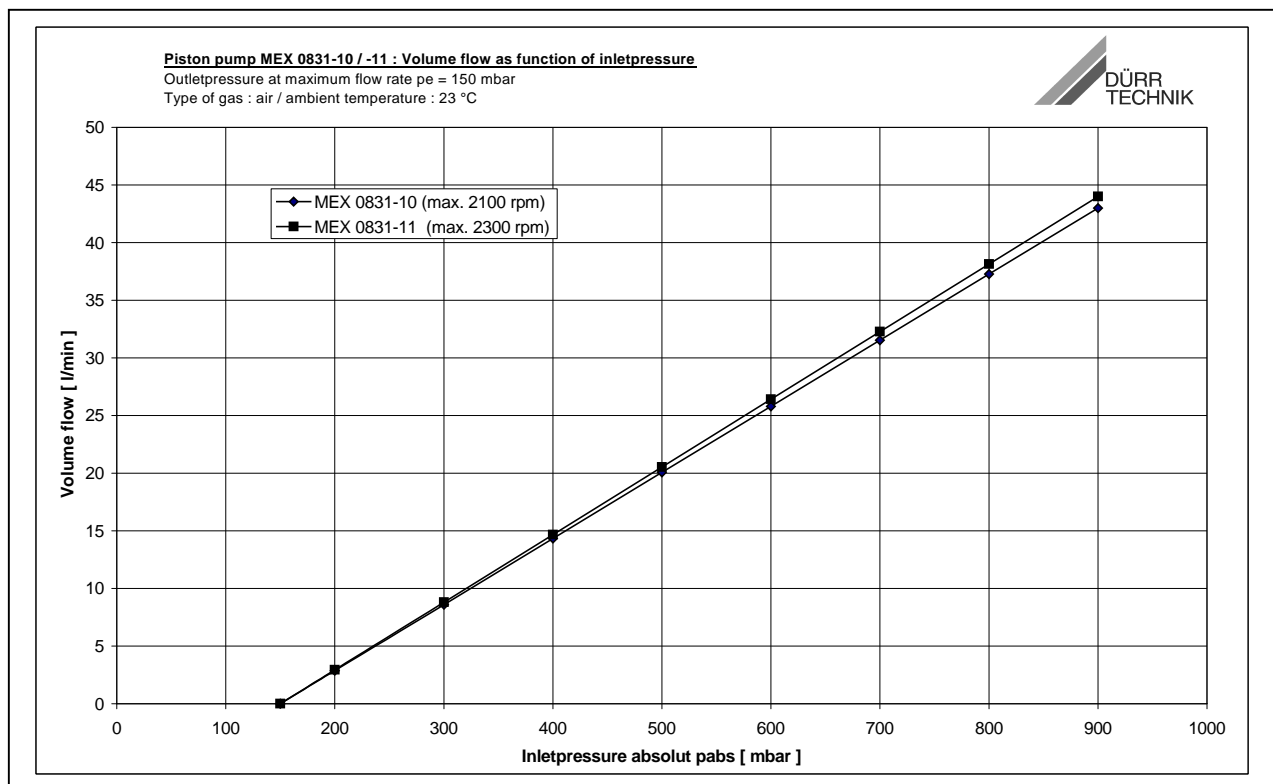

Fig.6

Flow characterisic

DECLARATION OF CONFORMITY



Manufacturer	Dürr Technik GmbH & Co. KG , Luft- und Processortechnik
Address	Pleidelsheimer Straße 30, D-74321 Bietigheim- Bissingen
Reference number:	See reverse
Article designation:	Vapour recovery pump
Description of the appliance:	<p>The type "MEX 0831-10" and "MEX 0831-11" vapour recovery pumps are vacuum pumps of a pendulum plunger construction with integrated flame arresters arranged on the inlet and outlet sides to suck off explosion-capable fuel vapour/air mixtures into vapour recovery devices of dispensing devices at filling stations.</p> <p>The vacuum pumps work in intermittent operation.</p> <p>Requirements of explosion protection of the appliance: Interior of the inlet and outlet line: demands according the Category 1 Surroundings of the vacuum pump: demands according to Category 2</p>
Description of the protection system	<p>The type "MEX 0831-10" and "MEX 0831-11" vapour recovery pumps are to be used as inline deflagration arrester and inline detonation arrester between the dispensing valve and the storage tank - in the gas return line - in order to prevent a flame breakthrough in deflagrations or stable detonations of explosion-capable vapour/air mixtures of explosion group IIA in the case of ignition on the dispensing valve and the following subsequent max. hose and pipe length:</p> <p>a) gas return hose with an internal diameter ≤ 10 mm in a coaxial hose ≤ 6 m, or optionally</p> <p>b) coaxial hose ≤ 6 m with an outer diameter ≤ 38 mm</p> <p>together with a subsequent ID 15 pipe (G ½") ≤ 3 m.</p> <p>The vapour recovery pumps (membrane or plunger pumps) each comprise a housing with pump parts (plunger pump). One flame arrester has been installed on each of the suction and pressure side of the pumps. The flame arrester - in the form of a crimped ribbon - comprises one corrugated and one smooth belt of non-rusting steel. The belts, each 10 mm in width and 0.2 mm in thickness, are rolled up in a spiral shape in dense layers. In this way, triangular-shaped channels of 0.7 mm at the most are formed, through which vapour/air mixtures can flow, with a flame breakthrough however being prevented. The design, materials and dimensions are stipulated by diagrams and part lists.</p>
CE marking from	Batch/serial number: see reverse.
<p>We hereby declare that the product described above fulfils the relevant provisions of Directive 94/9/EC of the Council of the European Communities of March 23, 1994. EC type test certificate number PTB 01 ATEX 5004 Notified body: Physikalisch-Technische Bundesanstalt, Bundesallee 100, D-38116 Braunschweig, ID no. 0102.</p> <p><i>The following applicable standards, directives and test rules were used:</i> Directive for machines 98/37/EC of 22.07.1998 Test rules of the PTB "Demands made of explosion-proof vacuum pumps" in combination with EN 1127-1 and EN 50014 as well as PTB test procedure "Flame arresters" on the basis of EN 12874.</p> <p>Special points: The type "MEX 0831-10" and "MEX 0831-11" vapour recovery pumps with the identification PTB 01 ATEX 5004 correspond to the type "MEX 0831-10" and "MEX 0831-11" vapour recovery pumps with the identification PTB no.. III B/S 2208 and PTB no. III B/S 2303 respectively as regards their construction and mode of function.</p>	
<p>Permissible ambient temperature -40 °C to +60 °C</p>	
Bietigheim- Bissingen, 16.05.06	ppa. H. Ripsam, Head of Dürr Technik
Proof of signature in the original document with Dürr Technik	

Reference No.	CE-Marking from batch-/ serial no.
0831-10/100	P001906
0831-10/101	P000103
0831-10/103	P002457
0831-11/600	P037500
0831-11/601	P000102
0831-11/603	R000100
0831-10+100	R001004
0831-10+101	R000100
0831-10+103	R001002
0831-11+600.	S000100
0831-11+601	R000100
0831-11+603	R000100